



CRANE SCALE



SALIENT FEATURES

- New Design PCB And Longer Standby Time
- Integral Design Of Load Cell, Quick, Accurate, Stable Weighing
- High Quality Rechargeable Battery And
- Impact Resistant Ms Powder Coated Body
- Perfect Software, Never System Halted
- Convenient Remote Controller

LED Display



Red

Green



TECHNICAL PARAMETERS

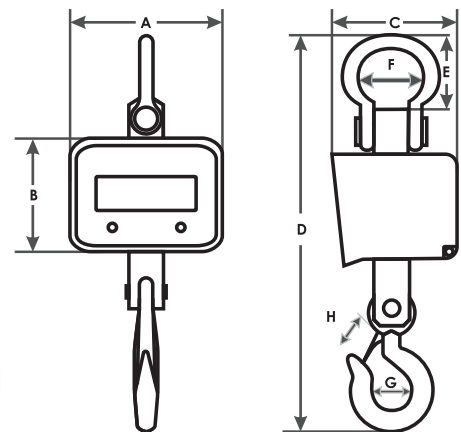

Product Code	Capacity	E Value	No Sub Division	Dimensions								Net Weight
				A	B	C	D	E	F	G	H	
	Kg	Kg		mm	mm	mm	mm	mm	mm	mm	mm	Kg
KECS02T-METAL	2000	1	2000	210	155	220	565	122	68.5	50	43	13.2
KECS03T-METAL	3000	1	3000	210	155	220	565	122	68.5	50	43	13.2
KECS05T-METAL	5000	2	2500	210	155	220	665	139	74	65	55	19
KECS10T-METAL	10000	5	2000	210	155	220	760	171	92	80	65	29
KECS15T-METAL	15000	5	3000	210	155	220	830	187	98.5	80	65	36
KECS20T-METAL	20000	5	4000	300	200	275	1000	235	127	100	85	85
KECS30T-METAL	30000	10	3000	300	200	275	1100	258	146	127	117	115
KECS50T-METAL	50000	20	5000	460	317	480	1450	310	233	160	130	340
KECS100T-METAL	100000	50	2000	475	248	375	1660	475	225	175	165	470

Due to progressive development of products, KEPTO reserve the right to alter the specifications shown within this catalogue without notice.