

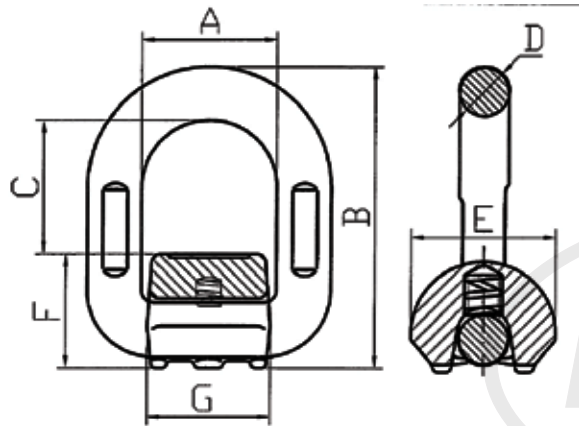

WELD ON RING

TECHNICAL PARAMETERS



Product Code	WLL (Ton)	BLL (Ton)	A (mm)	B (mm)	C (mm)	D (mm)	E (mm)	F (mm)	G (mm)	Weight (Kg)
8-SLR344-1T	1.12	4.48	41±1	80±2	35±2	13±1	38±2	33.5±1	37±1	0.47
8-SLR344-2T	2	8	42±1	90±2	41±2	14±1	40±2	36±1	38±1	0.51
8-SLR344-3T	3.15	12.6	46±1	96±2	42±2	17±1	43±2	37±1	44±1	0.69
8-SLR344-5T	5.3	21.2	55±1.5	121±3	48±2	22±1	61±3	50±2	50±2	1.46
8-SLR344-8T	8	32	70±1.5	144±3	62±3	26.5±2	70.5±3	54±2	66±2	2.52
8-SLR344-10T	10	50	85±2	168±4	78±3	28±3	76±3	62.5±2.5	78±3	3.59
8-SLR344-15T	15	60	97±2	187±4	86±3	34±3	90±3	72±3	90±3	5.79

Higher sizes are available on request. Due to continual development of products, manufacturer reserve the right to modify design, dimensional parameters and component material without prior notice.