



**SLR** <sup>®</sup> Since 1965  
RIGGING

# RIGGING HARDWARES

## WELD ON HOOK

### TECHNICAL PARAMETERS

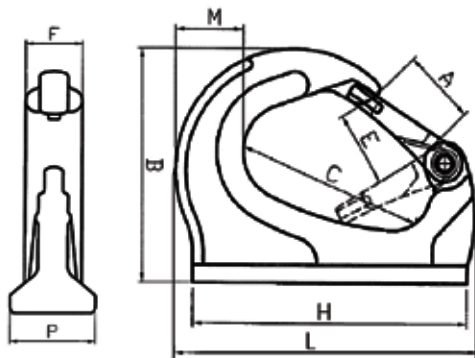

Product Code	WLL (Ton)	B.L. (Ton)	A (mm)	B (mm)	C (mm)	E (mm)	F (mm)	H (mm)	M (mm)	P (mm)	L (mm)	Weight (Kg)
8-SLR019-1T	1	5	23±1.5	76±1.5	63±1.5	22±2	18±1	93±2	22.5±1	25±1	101±2	0.54
8-SLR019-2T	2	10	28.5±1.5	92±1.5	66±1.5	26±2	20.5±1	81±2	23.3±1	34±1	111±2	0.87
8-SLR019-3T	3	15	30±2	106±2	75±2	30±2	24±1	116±2.5	30±1.5	36±1.5	128±2	1.27
8-SLR019-5T	5	25	39±2.5	133±2	98±2	36±2.5	28±2	160±2.5	43±1.5	43.5±1.5	170±2.5	2.7
8-SLR019-8T	8	40	36±2.5	137±3	99±2	34.5±2.5	39±2	166±2	50±1.5	51±1.5	175±2.5	3.5
8-SLR019-10T	10	50	49±2.5	169±3	140±3	49±2.5	38±2	205±2	55±2	53±2	222±3	5.20

Higher sizes are available on request. Due to continual development of products, manufacturer reserve the right to modify design, dimensional parameters and component material without prior notice.