



SLR [®] Since 1965
RIGGING

RIGGING HARDWARES

SELF LOCK CLEVIS HOOK

TECHNICAL PARAMETERS

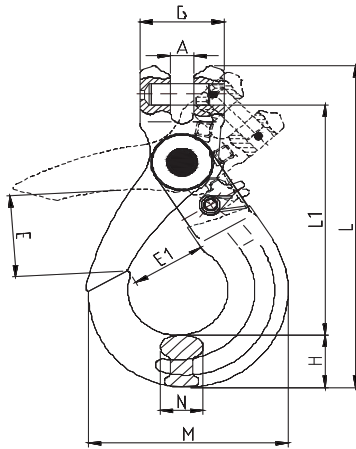

Product Code	WLL (Ton)	B.L. (Ton)	A (mm)	B (mm)	E (mm)	E1 (mm)	L1 (mm)	L (mm)	H (mm)	N (mm)	M (mm)	Weight (Kg)
8-SLR-738-06	1.12	4.48	8±0.5	32±1	32±2	28±1	99±3	134±3	20±1	15±0.5	73±2	0.45
8-SLR-738-7/8	2	8	9.5±0.5	38.5±1	40±3	35±1	119±3	162±3	26±1	20±0.5	91±2	0.85
8-SLR-738-10	3.15	12.6	12.5±0.5	46±1	48±3	45±2	142±3	195±3	30±1.5	26±1	108±2	1.48
8-SLR-738-13	5.3	21.2	15±0.5	59±1	57±3	52.5±2	179±4	248±4	40±1.5	33±1	142±3	2.85
8-SLR-738-16	8	32	18.5±0.5	77±1.5	65±4	63±2	225±4	310±4	50.5±2	38±2	168.6±3	6
8-SLR-738-18/20	12.5	50	24±1	81±1.5	82±4	82±2	238±5	335±5	55±2	50±2	185±4	7.5
8-SLR-738-22	15	60	25±1	97.5±2	80±5	76±3	277±5	392±5	67±2	52±2	202±4	12.28
8-SLR-738-26	21.2	84.8	30±1.5	118±2	109±5	96±4	312±6	449±6	75±3	60±3	239±5	21.8
8-SLR-738-32	31.5	126	35±1.5	150±2	131±6	131±4	416±6	590±6	97±3	79.5±3	329±5	46

Higher sizes are available on request. Due to continual development of products, manufacturer reserve the right to modify design, dimensional parameters and component material without prior notice.