



**SLR** <sup>®</sup> Since 1965  
RIGGING

# RIGGING HARDWARES

## CLEVIS GRAB HOOK

### TECHNICAL PARAMETERS

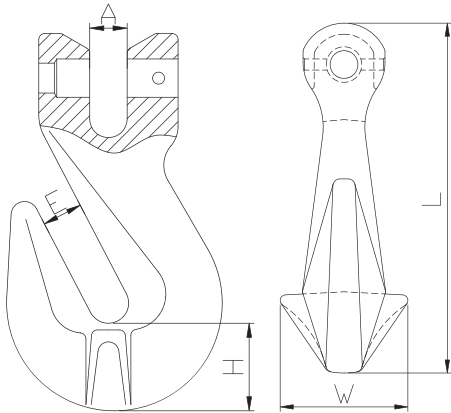

Product Code	WLL (Ton)	B.L. (Ton)	E (mm)	A (mm)	B (mm)	W (mm)	L (mm)	L' (mm)	M (mm)
8-SLR086-06	1.12	4.48	8±0.5	7.5±0.5	32±1	21.5±1	77±2	45±2	45±2
8-SLR086-7/8	2	8	10.5±0.5	9.5±0.5	39±1	34.5±1	89±2	53±2	53±2
8-SLR086-10	3.15	12.6	13±0.5	12.5±0.5	46.5±2	46±1	126±3	75±3	71±3
8-SLR086-13	5.3	21.2	16.5±1	15±1	53±2	57.5±2	163.5±3	92±3	96±3
8-SLR086-16	8	32	19±1	18.5±1	69.5±2	74±2	183.5±3	99±3	113±3
8-SLR086-20	12.5	50	24±1.5	23±1	81±3	74±2	219±3	123±3	143±3
8-SLR086-22	15	60	27±1.5	27±1	91±3	90±2	254±4	140±4	160±4
8-SLR086-26	21.2	84.8	30±1.5	30±1	117±3	102±2	309±4	187±4	181±4

Higher sizes are available on request. Due to continual development of products, manufacturer reserve the right to modify design, dimensional parameters and component material without prior notice