

# TECHNICAL PARAMETERS

**Heavy duty**

Capacity		Tonnes	1						2						3					
Item Code	KIRH		4010206	4010209	4010412	4010418	4010424	4010430	4020206	4020209	4020412	4020418	4020424	4020430	4030206	4030209	4030412	4030418	4030424	4030430
Mechanism Class As Per IS:3938			II						II						II					
Height Of Lift	Mtr.		6	9	12	18	24	30	6	9	12	18	24	30	6	9	12	18	24	30
No Of Rope Fall			2			4			2			4			2			4		
Rope Dia	mm		8						10						12					
Specification Of Hoisting Drive	Lifting Speed (Mtr/min)	Type A	3	3	3	3	3	3	3	3	3	3	3	3	3	3	3	3	3	3
		Type B	6	6	6	6	6	6	6	6	6	6	6	6	6	6	6	6	6	6
	Motor Power(Kw)	Type A	1.1	1.1	1.1	1.1	1.5	1.5	1.5	1.5	2.2	2.2	2.2	2.2	3.7	3.7	3.7	3.7	3.7	3.7
		Type B	1.5	1.5	1.5	1.5	2.2	2.2	3.7	3.7	3.7	3.7	3.7	3.7	5.5	5.5	5.5	5.5	5.5	5.5
Specification Of Cross Travel Drive	Lifting Speed (Mtr/min)	Type A	10						10						10					
		Type B	0.37						0.37						0.37					
	Motor Power(Kw)	Type A	18						18						18					
		Type B	0.37						0.37						0.5					
Brake For Hoist		ACEM/EHT																		
Brake For Cross Travel Trolley		EM DISC																		
Dimension	A	mm	900	900	900	900	900	900	1000	1000	1000	1000	1000	1000	1100	1100	1100	1100	1100	1100
	B	mm	850	850	850	850	850	850	900	900	900	900	900	900	920	920	920	920	920	920
	C	mm	400	400	400	400	400	400	440	440	440	440	440	440	440	440	440	440	440	440
	D	mm	450	450	450	450	450	450	460	460	460	460	460	460	480	480	480	480	480	480
	E	mm	664	664	664	664	664	664	720	720	720	720	720	720	750	750	750	750	750	750
	F	mm	1040	1090	1392	1626	1861	2095	1090	1160	1527	1820	2100	2400	1140	1224	1650	1900	2250	2550
	G	mm	540	590	892	1126	1361	1595	590	660	1027	1320	1600	1900	640	724	1150	1400	1750	2050
Suitable Flange Width	mm	ISMB 200 X 100 - 300 X 140						ISMB 200 X 100 - 300 X 140						ISMB 250 X 125 - 350 X 150						
Approx Weight	Kg	700	750	825	880	950	1050	750	800	950	1000	1050	1100	885	950	1000	1150	1280	1400	

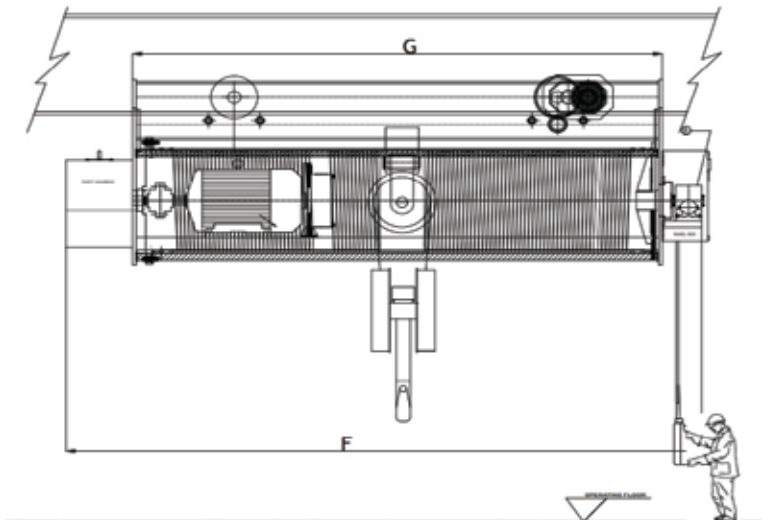
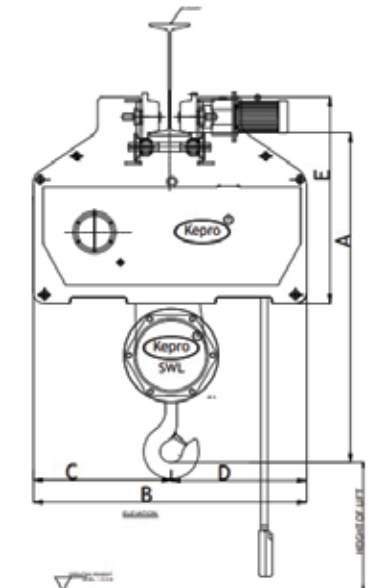

# TECHNICAL PARAMETERS

**Heavy duty**

Capacity		Tonnes	5						7.5						10					
Item Code		KIRH	4050206	4050209	4050412	4050418	4050424	4050430	4075206	4075209	4075412	4075418	4075424	4075430	4100206	4100209	4100412	4100418	4100424	4100430
Mechanism Class As Per IS:3938			II						II						II					
Height Of Lift		Mtr.	6	9	12	18	24	30	6	9	12	18	24	30	6	9	12	18	24	30
No Of Rope Fall			2			4			2			4			2			4		
Rope Dia		mm	14						16						16					
Specification Of Hoisting Drive	Lifting Speed (Mtr/min)	Type A	3	3	3	3	3	3	3	3	3	3	3	3	3	3	3	3	3	3
		Type B	6	6	6	6	6	6	6	6	6	6	6	6	6	6	6	6	6	6
	Motor Power(Kw)	Type A	5.5	5.5	5.5	5.5	5.5	5.5	7.5	7.5	7.5	7.5	7.5	7.5	9.3	9.3	9.3	9.3	9.3	9.3
		Type B	7.5	7.5	7.5	7.5	7.5	7.5	9.3	9.3	9.3	9.3	9.3	9.3	13	13	13	13	13	13
Specification Of Cross Travel Drive	Lifting Speed (Mtr/min)	Type A	10						10						10					
		Type B	0.37						0.37						0.37					
	Motor Power(Kw)	Type A	18						18						18					
		Type B	0.5						0.5						0.75					
Brake For Hoist			ACEM/EHT																	
Brake For Cross Travel Trolley			EM DISC																	
Dimension	A	mm	1200	1200	1200	1200	1200	1200	1400	1400	1400	1400	1400	1400	1600	1600	1600	1600	1600	1600
	B	mm	1050	1050	1050	1050	1050	1050	1088	1088	1088	1088	1088	1088	1220	1220	1220	1220	1220	1220
	C	mm	520	520	520	520	520	520	520	520	520	520	520	520	605	605	605	605	605	605
	D	mm	530	530	530	530	530	530	568	568	568	568	568	568	615	615	615	615	615	615
	E	mm	826	826	826	826	826	826	826	826	826	826	826	826	925	925	925	925	925	925
	F	mm	1425	1224	1650	1900	2250	2550	1550	1700	1800	2150	2500	2850	1440	1616	1800	2200	2500	2850
	G	mm	825	724	1150	1400	1750	2050	950	1100	1200	1550	1900	2250	840	1016	1200	1600	1900	2250
Suitable Flange Width		mm	ISMB 250 X 125 - 350 X 150						ISMB 300X140 - 500 X 180						ISMB 400X140 - 600 X 210					
Approx Weight		Kg	900	950	1000	1150	1280	1400	960	1030	1170	1320	1480	1630	1200	1300	1400	1500	1800	2000

